

RAVAS ProLine 5200 / 5200 INOX

Custom designed for professional use with touch screen indicator



BENEFITS

- Superb accuracy
- Rotating and tiltable indicator
- 5 inch touch screen with 25 mm high digits
- High capacity Li-ion battery pack for 25 hours of autonomy
- Optimal ease of use, only active keys visible
- Customer specific routines can be programmed
- Integrated data connectivity
- Counting scale functionality
- Level compensation to 3 degrees
- RAVAS ProLine 5200 INOX: Full stainless steel chassis

The hi-tech standard
Extremely accurate

PROLINE 5200 INOX



RAVAS

FUNCTIONS

- Automatic and manual zero correction
- Gross / net weighing
- Tare memory for 10 values
- ID-code entry for 4 ID-codes with 10 preset codes (each max.14 characters alpha-numeric)
- 10 totalizing registers
- Internal clock for date and time
- On board: RS232 port connection for printer
USB output for data transfer (with USB Stick)
Free COM 1 and COM2 for connection to RS232, WiFi or devices that have Bluetooth® technology
- The USB output can also be used to connect a bar-code scanner
- Connectivity for RAVAS Indicator App
- Sleep modes for saving power.
- Error message in display incl. logging

STANDARD SPECIFICATIONS

- Capacity 2,000 kg
- Graduation multi-range
0 - 200 kg: graduation 0.1 kg
200 - 400 kg: graduation 0.2 kg
400 - 2.000 kg: graduation 0.5 kg
- System tolerance 0.08 % of applied load
- Display full-colour 5" touch display with 25 mm high digits
- Power consumption 12V -160 mA
- Power supply Li-ion battery pack 14.8V / 5Ah incl. charger
- Autonomy 25 hours continuous use (50 hours with sleep modes)
- Keyboard display mode defines the available keys, on/off key
- Protection class Loadcells IP 67, indicator IP65
- Indicator mounting rotating and tiltable
- Steering wheels rubber
- Loading wheels polyurethane, tandem
- Pump ergonomic lift
- Own weight 180 kg
- Colour Chassis red (RAL3000)
Fork shoe black (RAL9005)
Epoxy painted
- Colour INOX stainless steel

DIMENSIONS IN MM

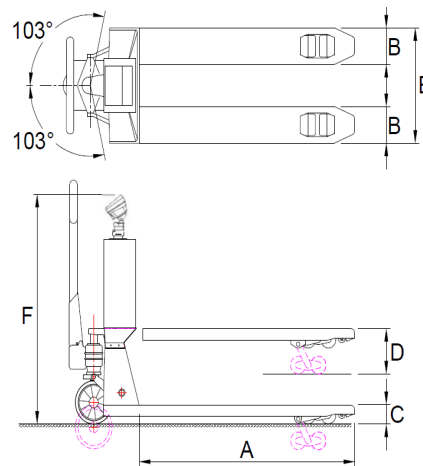

	Standard chassis	Stainless chassis
A Fork length	1150	1150
B Fork width	160	160
C Minimum fork height	90	90
Minimum clearance	22	22
D Maximum fork height	205	205
E Width over forks	550	550
F Height to top indicator	1260	1260

Loading wheels

- type: PU tandem yes no
- type: PU single no no
- type: Nylon tandem no yes

Steering wheels

- type: rubber yes no
- type: Nylon no yes



Management System
ISO 9001:2015
ISO 14001:2015
ISO 45001:2018
www.tuv.com
ID 0000037200

OPTIONS*

- Legal for trade version, OIML III
- Extra exchangeable Li-ion battery pack
- Built-in thermal printer
- Data transfer to devices that have WiFi or Bluetooth® technology
- Relay setpoint switch for automatic dosing
- Stainless steel fork shoes
- Reference scale via RS232 (for more accurate piece counting)
- 1D USB bar-code scanner
- Footbrake
- Different fork dimensions
- Different steering or loading wheels
- RDC, RAVAS Data Collector Software
- RIS, RAVAS Integration Software

RAVAS Europe B.V.

Veilingweg 17, 5301 KM Zaltbommel, The Netherlands

T: +31 418 515220 E: salesoffice@ravas.com

WWW.RAVAS.COM

